

5000 Series

100 to 130 HP



ARBOS



Arbos 5000 Series

Arbos value	p. 4
Design	p. 6
Engine	p. 8
Transmission	p. 10
Hydraulics and lift	p. 12
Cab	p. 14
Versatility	p. 16
Technical specifications	p. 18





Quality

Top value for



Designed and developed by Lovol Arbos, in the 100 to 130 HP power sector the 5000 Series offers excellent performance, great efficiency and the highest reliability standards. It is designed with attention to detail and the guarantee of the most stringent tests on the bench and in the field.

3 key elements are at the heart of the design:

- a "Value for Money" design: the best technology available, but without neglecting the quality/price ratio
- compliance with European product and process standards, and component and assembly quality
- a fresh, original look and car-style comfort.

Modern, versatile, professional: Arbos 5000 Series, the new, alternative answer to the requirements of agricultural businesses and operators.

money



A UNIQUE STYLE

A captivating, modern and practical look, rounded and tapered lines that while also increasing structural strength keep the overall dimensions compact and make steering easy. A distinctive and modern style, designed for the global market, that people like at first sight, thanks to the talent of the European style centre. The bonnet and the cab give the line its distinctive look:

- the monolithic bonnet made of SMC, smooth and elegant, is the characteristic feature of the front end of the 5000 Series, with the built-in headlight strip framing the logo. The pearlescent white side panels create a harmonious contrast with the green Arbos livery, for a modern take on the brand's original colours. The "shark gill" slits in the side panels, easily removable for extraordinary maintenance and designed to optimise outflow, accentuate the overall aggressive look, whilst the rational opening/closing system makes routine maintenance easy, combining style and functionality.

The elegant lines of the bonnet extend without a break into the cab: the curved windscreen, sturdy uprights, the thin roof profile with side attachments and the full set of front and rear work lights are harmoniously combined and accentuate the strong, unique character of the new 5000 Series.



Beautiful & friendly





KOHLER 3404 TCR SCR

- 4 cylinders 3,400 cc Tier IV f
- Max. power 136 HP (95% available at 1900 rpm)
- Max. torque 500 Nm at 1400 rpm
- 95% of Max. torque available from 1300 to 1800 rpm
- Starting torque 410 Nm and 36% torque increase
- Specific consumption 205 g / kWh



“Diesel of the

For the 5000 Series, we couldn't just settle for any engine: we wanted one that was innovative, efficient, fuel saving and 100% reliable. We found it: the Kohler 3404 TCR SCR Tier IV F, four cylinders with 3400 cc, outstanding in the agricultural engines sector. No wonder it was nominated “Diesel of the Year” 2015. Today the Arbos 5000 range offers four models from 100 to 130 HP, with maximum



year'' 2015

power of up to 136 HP and 95% of torque available between 1300 and 1800 rpm. One of the many exclusive features of these engines is the compact SCR system (with integrated DOC) installed on the exhaust: the result is a bonnet with tapered, encircling lines, elegant and distinctive, practical for a reduced turning radius.





Smooth

HEAVY DUTY FRONT AXLE

From the front axle to the rear one, the powertrain is made to transmit all of the power available to the ground with maximum efficiency, simplifying work in any operating condition. The Heavy Duty front axle, in particular, was purpose-designed for this product range, where sturdiness, manoeuvrability and a high load capacity are essential. The 100% differential lock with mechanical or electro-hydraulic control and the option of front braking, further emphasise the value of the design.

The practical consequences?

High load capacity on the axle (3,500 kg), important when using a front loader, and excellent handling, with a steering lock angle of up to 55°.

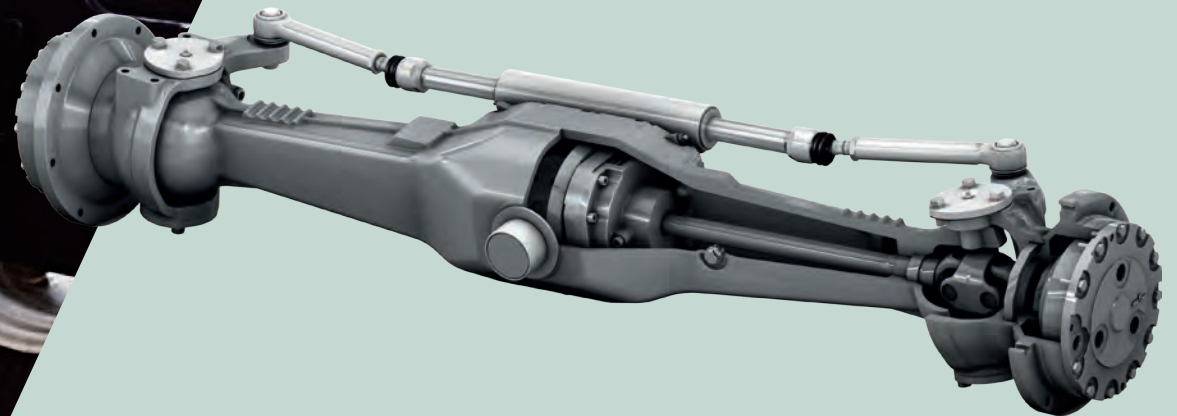

efficiency

MODULAR TRANSMISSION, IN MANY CONFIGURATIONS

Designing a transmission that is simple but efficient, modern and relentless, but not complicated and expensive: the challenge faced by the Arbos design department was one of the most complex. The result is clear to see: an “accessible” transmission, in line with current technical solutions, sturdy and reliable in all conditions, as demonstrated by many rigorous field tests.

The basic design was developed in three different configurations: Entry Level, Global, Advanced. The different respective features:

- **Entry Level:** a fully mechanical synchronised gearbox, with mechanical engagement controls for 4WD, Diff lock and PTO
- **Global:** the intermediate alternative, a 2-stage gearbox with shifting under load and mechanical synchronised shuttle
- **Advanced:** top of the range, a 3-stage Semipowershift with hydraulic shuttle located under the steering wheel and electro-hydraulic controls for 4WD, Diff lock and PTO with independent hydraulic clutch.

For all variants, 5 gears and 3 working ranges, with creeper for ultra-slow speeds from 0.33 km/h, exceptionally reduced power absorption, maximum speed of 50 km/h (40 km/h at economy rpm 1840). The powershift gearbox guarantees ideal coverage of working speeds with the most commonly used implements, precise selection of the gears and a +/- 20% under load reduction, having an impressive 12 gears between 4 and 12 km/h: the “Implement Powershift” is a smart system that guarantees efficiency, ideal speed in any condition and comfort for the operator, who controls the gear change using the buttons under the gear lever.

What about safety in the field?

The versions with power shuttle also offer a hydraulic Park Lock, alongside the more traditional hand brake supplied on versions with the mechanical shuttle.

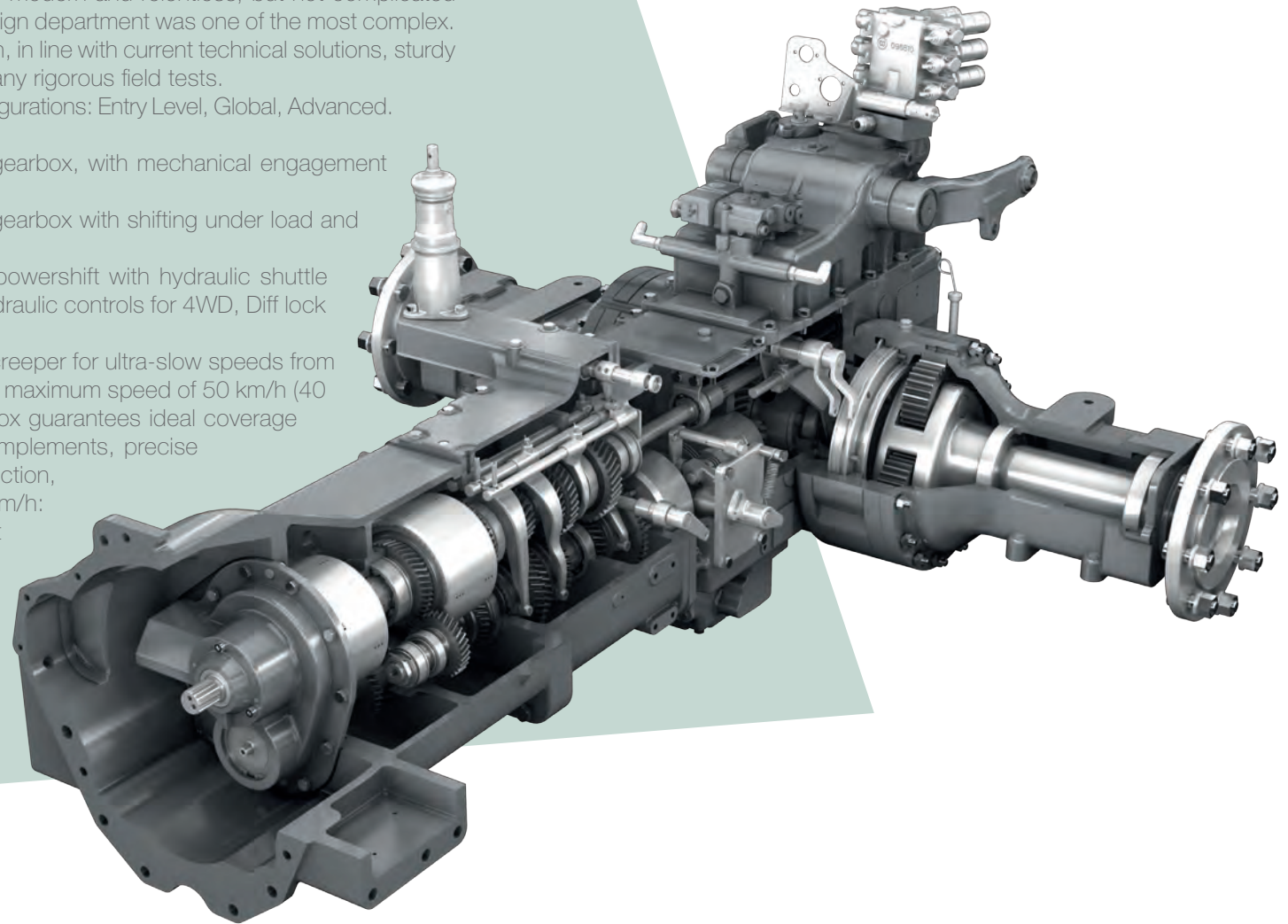



Move and Lift

PTO: 4 SPEEDS AVAILABLE

Important original design solutions are also seen in the PTO which, depending on the versions, is always available with an independent dry clutch and mechanical control in the cab, or with a more modern PTO with hydraulic clutch and electro-hydraulic control. For both versions, 4 speeds are available: the traditional ones 540/1000 and the respective ECO versions, to make the best possible use of the implements and save fuel.



A HYDRAULIC SYSTEM FOR EVERY REQUIREMENT

For the hydraulic system too, "versatility" is the key word: from the more traditional mechanical lift - with a useful, intuitive Easy Lift device for return and descent to the preset position, to the electronic lift with height, depth, force and position adjustment, for those who demand maximum precision and comfort.

Both versions come with high lifting capacity (4,400 kg) so that the implements carried can easily be used. The auxiliary control valves for hydraulically powering the implements interact with a high flow rate system 110 l/min., of which up to 70 l/min. are dedicated specifically to implement movement. Up to 3 double-acting mechanical control valves with detent, kick out and floating functions, plus a handy electric switch for a further pair of outlets, make use of the various implements even easier for all farming work.





The

INTERIORS: TRULY ERGONOMIC

Intuitive and easy man-machine interaction - in terms of position, load and travel of the levers - are what the cab is designed around. The shuttle shift under the steering wheel (mechanical-synchronised or hydraulic) is handy and practical both with the front loader and in bunker silos, like the levers for the gears, the lift and auxiliary control valves, always within reach. The electro-hydraulic buttons for the diff lock and 4WD make manoeuvring operations immediate and instinctive. In the cab, amongst the many interesting solutions, comfort is enhanced by the steering column (double adjustment: angle and height) with a 3-spoke steering wheel and power steering. The light, heating and air conditioning controls are rationally laid out on the dashboard. The powerful climate control unit (completely under the bonnet, with a short and therefore highly efficient circuit) and the outlets and the special curve of the windows, optimise air circulation, giving uniform air conditioning, without hot and cold peaks. The 5000 Series is available with a traditional analogue display or with a more modern 7 inch TFT digital display, having a simple, customisable interface.

cockpit

CAB: CAR-STYLE COMFORT

Stylish, comfortable, practical: the inside of the cab is like that of a car, designed for well-being and ergonomics. It is ideal for long working days, successfully combining visibility, comfort and maximum safety.

Perfect pressurisation, reduced noise level, a microclimate that is comfortable and the same in all seasons and at all times of day. All of this plus an easily accessible, comfortable driving position.

The extensive 360° glass surface (forward visibility angle 42° up, back 30° down) guarantees exceptional visibility and facilitates operations with the front loader and using implements connected to the back.

The cab design is based on a cutting-edge engineering approach, with a structure that distributes stresses over the entire surface, making it safer and optimising the weight/power ratio, thanks to a weight that is one third lower than traditional solutions.

The thin roof profile also reduces the tractor's overall height and makes it easier to gauge dimensions where access may be difficult.

Elegance, comfort, visibility and safety: this product is hard to beat!





The multipurpose,

VERSATILITY FIRST AND FOREMOST

Examine them carefully, look at them from every angle, touch them and try them out: every detail of an Arbos 5000 series tractor puts versatility first and foremost, the real strong point of this Utility tractor.

No surprises: the guidelines for the entire design were farmers' real requirements, and the desire to focus only on what really matters.

The result is here for all to see: efficient, economical, modern and sturdy tractors, without excluding technology, but created for those with a no-nonsense attitude, who know what they want, all substance with few frills.

With a prestigious design and a state of the art cab.

With a sturdy, efficient front axle and minimal maintenance.

With perfect tractor - implement integration and a broad application spectrum.

Everything - compact dimensions, weight distribution, performance, consumption and emissions - was meticulously developed in the new 5000 Series, the new multi-purpose tractors balanced during all types of use.

Arbos 5000 Series, versatility as added value.



redefined

Automotive-style cab

Engine of the Year 2015

Efficient transmission

Heavy duty front axle



TECHNICAL SPECIFICATIONS

ENGINE	ARBOS 5100				ARBOS 5110				ARBOS 5120				ARBOS 5130					
	4WD				4WD				4WD				4WD					
Model	Kohler Tier IV Final																	
Cylinders/Displacement	N°/cm³		4/3404															
Aspiration	Turbo intercooler																	
Injection system	2000 bar Common Rail																	
Valves	16 valves																	
Max. homologated power (2000/25/CE)	HP/KW		102/75				110/80				122/90				136/100			
Nominal engine speed	rpm		2200															
Max. torque	Nm		470				475				480				500			
Max. torque engine speed	rpm		1400				1400				1400				1400			
Cooling	Liquid-Oil - Gas (EGR)																	
Engine control	electronic																	
Air cleaner	dry with safety cartridge and dust ejector																	
Silencer	underhood with exhaust on cab upright																	
After treatment system	DOC+ SCR integrated on rear side pillar																	
Ad-Blue fuel tank capacity	25																	
Fuel tank capacity	litres		145															

TRANSMISSION ENTRY LEVEL

Clutch		12" double dry clutch	12" HD double dry clutch	13" double dry clutch
Gearstep		5		
Range		2		
Creep		OPT		
Speed	FWD+REV	15+15		
Max. speed		40Kph		
Shuttle		Mechanical shuttle with lever under steering wheel		
4WD		Mechanical engagement		
Differential lock		Limited slip 50% auto; 100% diff lock with mechanical engagement		

Rear P.T.O

Clutch		Dry clutch independent		
Speed	rpm	540-1000 or 540E-1000		
Operation		mechanical operated with lever		

TRANSMISSION GLOBAL

Clutch		12" double dry clutch	12" HD double dry clutch	13" double dry clutch, hydraulically operated
Gearstep		5		
Range		2		
Creep		OPT		
Speed	FWD+REV	30 + 30 (2 speed Powershift underload)		
Max. speed		50 Km/h limited by electronic regulator to 40Km/h* at nominal engine speed and economy engine speed (1840 rpm)		
Shuttle		Mechanical shuttle with lever under steering wheel		
4WD		Electrohydraulic engagement		
Differential lock		Limited slip 50% auto; 100% diff lock with electrohydraulic engagement		

Rear P.T.O

Clutch		Dry clutch independent		
Speed	rpm	540-1000 or 540E-1000		
Operation		mechanical operated with lever		

TRANSMISSION ADVANCED	ARBOS 5100				ARBOS 5110				ARBOS 5120				ARBOS 5130			
	4WD				4WD				4WD				4WD			
Clutch	WET clutch, hydraulically operated															
Gearstep	5															
Range	2															
Creep	OPT															
Speed	FWD+REV	45+15 (3 speed Powershift underload)														
Max. speed		50 Km/h limited by electronic regulator to 40Km/h* at nominal engine speed and economy engine speed (1840 rpm)														
Shuttle	Powershuttle with lever under steering wheel															
4WD	Electrohydraulic engagement															
Differential lock	Limited slip 50% auto; 100% diff lock with electrohydraulic engagement															

Rear P.T.O

Clutch		WET clutch		
Speed	rpm	540/540E /1000 /1000E		
Operation		electrohydraulic operated with pushbutton		

BRAKES AND STEERING

Braking system		hydrostatically operated, wet disks on rear wheels, 4WD engagement		
		all wheel braking, WET disks on all 4 wheels, hydrostatically operated		
Trailer braking valve		hydraulic		
		pneumatic		
Hydrostatic steering		STD		
Steering angle		55°		

FRONT AXLE

Type		conventional		
Front ballast		13 40 Kg case type weights (total 520 Kg)		
Front mudguards		steering		

HYDRAULIC LIFT

Rear lift		mechanical with Easylift / electronic rear lift		
Maximum lifting capacity	Kg	4.400 Kg (with external cylinder)		
Pump delivery	l/min	Gear pump total 110 l/min		
		70 l/min dedicated to implements		
Auxiliary hydraulic control valves	Ways	2/3 mechanical spoolvalves + electrohydraulic flow diverter (total 3+1 spool valves)		
3 point linkage (link arms and top link)		Cat II arms with mechanical fixing point or quick adjustment, hydraulic top link		
Front lift		double acting cylinders		
		maximum lifting capacity 2000 Kg.		
		quick ballast 850 Kg		

DRIVING POSITION

Cab	original sound-proofed (72 dBA), with silent block mounted platform, high visibility roof with rounded glass, up to 10 worklights (4 rear + 6 front)		
	telescopic rear-view mirrors		
Cab conditioning	air conditioning with ventilation, heating, forced recirculation		
Instruments	analog / TFT 7" digital display		
Driver's seat	mechanical adjustment, safety belt		
	pneumatic suspension, safety belt		



DIMENSIONS AND WEIGHTS: with rear tyres		ARBOS 5100	ARBOS 5110	ARBOS 5120	ARBOS 5130
		4WD	4WD	4WD	4WD
		480/70 R34 Rear 380/70 R24 Front	540/65 R34 Rear 440/65 R24 Front	480/70 R34 Rear 440/65 R28 Front	600/65 R38 Rear 440/65 R28 Front
Max. length at link arms	mm	4.249	4.249	4.299	4.299
Min - Max. width	mm	1916-2348	1976 - 2408	1916-2348	1966 - 2538
Max height at cab	mm	2.644	2.670	2.684	2.756
Ground clearance	mm	452	452	452	524
Wheelbase	mm	2.347	2.347	2.397	2.397
Front track min - max.	mm	1559-2013	1559-2013	1559-2013	1559-2013
Rear track min - max	mm	1436-1868	1436-1868	1436-1868	1366-1938
Weight with cab (W/out ballast)	Kg	4.000	4.100	4.200	4.200



LOVOL ARBOS SPA _ Via Cavour 1_ 42012 Calderara di Reno (BO) ITALY _ www.lovolarbos.com



www.maestristudio.com